

POWER INFORMATION

Input Voltage: 100-240 VAC
 Input Frequency: 50/60 Hz
 Amperage: 0.2 A @ 120 VAC
 Electric Consumption: 24 W
 Plug: Country-specific

SIZING INFORMATION

Specified by volume or odor sources

AC-05: small, single closet
 AC-10: small to medium, ≤3 odor sources
 AC-20: medium, ≤6 odor sources
 AC-30: large, >6 odor sources
 High trafficked areas may require a larger model.
 Large areas may require multiple units.

FEATURES

Wall Plug or Mains Installation
 13 foot Power Cord (4 meters)
 Ceiling or Wall Mount Kit
 Space Saving Design

APPLICATIONS

Virus and Bacteria Disinfection
 Washroom / Restroom Odor Control
 Fixed Virus Shield
 Care Homes / Nursing Homes
 Food Odor Removal
 Garbage Collection Areas
 Smoke Removal

WARRANTY

One year parts and labor on entire unit

AirCare System



Top View



Side View



End View

- Reduce bacteria, viruses, mold, and other micro-contaminants
- Eliminate odors, smoke, and chemicals
- Improve the hygiene in the air and on surfaces
- Certified to be safe, proven to be effective
- Designed specifically for Restrooms/Washrooms – and more
- Portable or fixed installations
- Completely automated and chemical-free
- Minimal Maintenance – requires simple annual UV lamp replacement

Product Certifications:



© BioZone Scientific International, Inc.

7616 Southland Blvd
 Suite 114
 Orlando, FL 32809
 USA



AirCare 05, 10, 20, 30
Product Family: AirCare
Model: AC-05, AC-10, AC-20, AC-30
Description: Air and Surface Purifier



REORDER INFORMATION

Replacement UV Lamps

AC-05: 10-08010
 AC-10: 10-08025
 AC-20: 10-08050
 AC-30: 10-08100

SPECIFICATIONS

Length: 16.2"
 Width: 5.2"
 Height: 3.65"
 Weight: 2.5 lbs
 Power Cord Length: 13'

CONTENTS

AirCare
 UV Lamp (pre-installed)
 Owner's Manual and Installation Guide
 Lock Key
 Wall Anchor (optional)
 Mounting Screws (optional)

VALIDATION STUDIES

BioZone Technology is shown to reduce:

- >99.999 of Avian Influenza Virus (H5N2)¹
- >99.999 of Parainfluenza Virus (hPIV-3)¹
- >99.999% of surface E. coli^{2,3}
- >99.999% of surface Listeria³
- 100% of surface Salmonella³
- 98.24% of airborne bacteria⁴
- 100% of airborne H₂S⁵

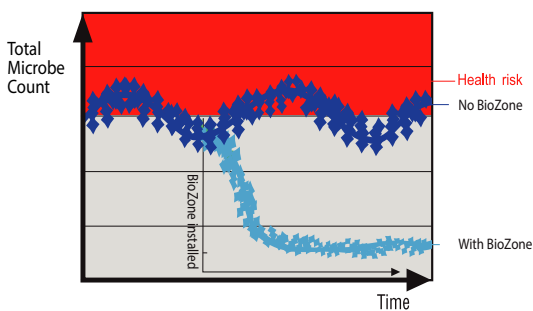

1 Test performed by CNRS
 2 Test performed by Pennsylvania State University
 3 Test performed by Tri-Tech Analytical Laboratories
 4 Test performed by LAWN Environmental Ltd
 5 Test performed by SMQ Academy

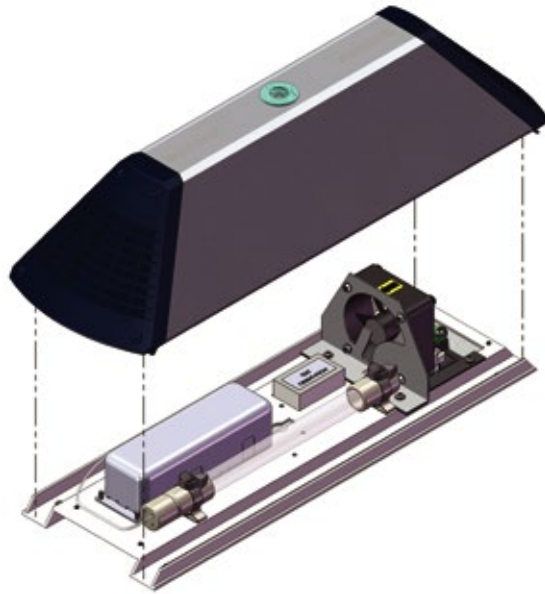

AC with cover removed

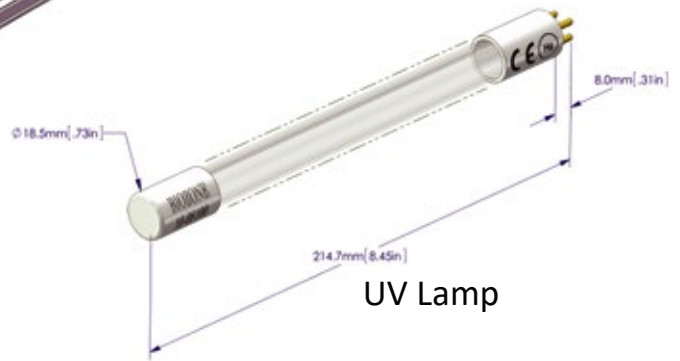

UV Lamp



Dimensions

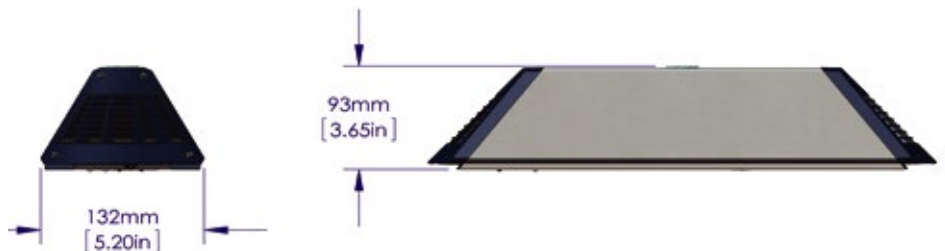

© BioZone Scientific International, Inc.

7616 Southland Blvd
 Suite 114
 Orlando, FL 32809
 USA

